

# Colorado Space Grant Consortium Citizen Explorer 1 Mission

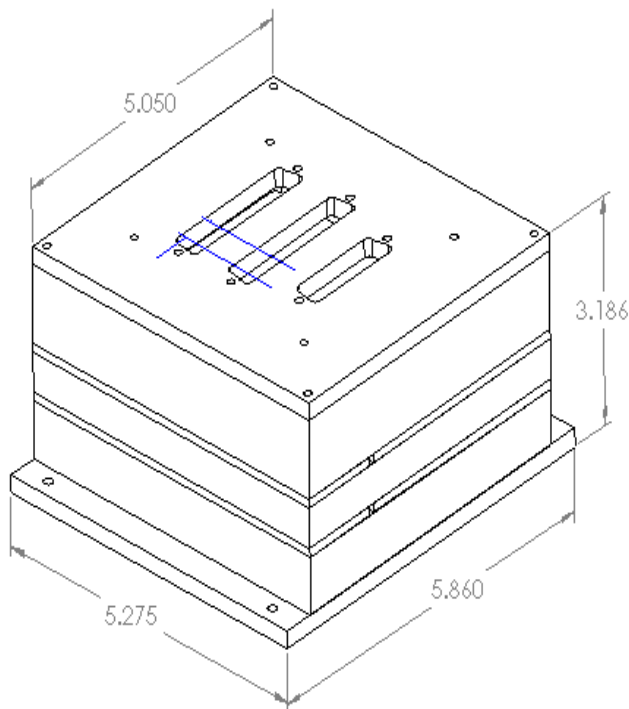

## Command and Data Handling System (CDH) "Baby Blue" flight computer fact sheet



### System configuration as flying on CX-1:

CPU (Central Processing Unit)	Intel 80386SX
Speed	25MHz
RAM	8MB
ROM	1MB (DOS drive C:)
SSD (Solid-State Disk)	8MB (DOS drive D:)
Power Consumption	3.31W in nominal mode 0.89W* in critical mode (no CPU)
CPU / SSD	+5V @ 400mA (2W) +12V @ 35mA (0.42W)
Critical Decoder	+5V @ 150mA (0.75W)* +15V @ 5mA (0.07W)* -15V @ 5mA (0.07W)*
Volume	5.3" X 5.9" X 3.2"
Mass	2 Kg*
Cost	\$2000 approximate

The Citizen Explorer "Baby Blue" flight computer is an extremely low-cost spacecraft computing platform built from commercial-off-the-shelf (COTS) industrial components with minor modifications for spaceflight.

Commercial-off-the-shelf components designed for industrial control provide a well-engineered, rugged, and inexpensive platform.

PC-compatible components in the PC/104 form factor provide for rapid software development on inexpensive desktop hardware, inexpensive low lead-time flight components, a wealth of development tools, and scalability to processing, data storage, and power consumption requirements (CPU boards are available from 8086 to "Pentium" CPUs, and SSDs are available from 1MB to 24MB and larger).

Modifications for spaceflight include a housing designed for conductive heat removal and radiation protection, and a "Critical Decoder" which monitors the main CPU for faults and can respond to limited ground commands even while the main CPU is powered down. The Critical Decoder also provides communications protocol management. Management is performed entirely in firmware and separate from the main CPU for development and operations flexibility.

High-level I/O consists of two standard PC serial ports and one parallel port. One serial port is dedicated to an RS-485 communications network for control of other spacecraft subsystems. The other serial port is dedicated to the communications system interface. The parallel port is unused on Citizen Explorer. Low-level I/O consists of 38 analog inputs and 16 digital I/O points available to the Critical Decoder.

This system is not radiation-hardened. However, it is designed to facilitate both automatic and ground-based recovery from radiation-induced errors. This system is designed to provide a high percentage of the functionality of a radiation-hardened computer, for a small percentage of the cost, in a package geared towards the needs of a university-level development program.

\* Estimated